

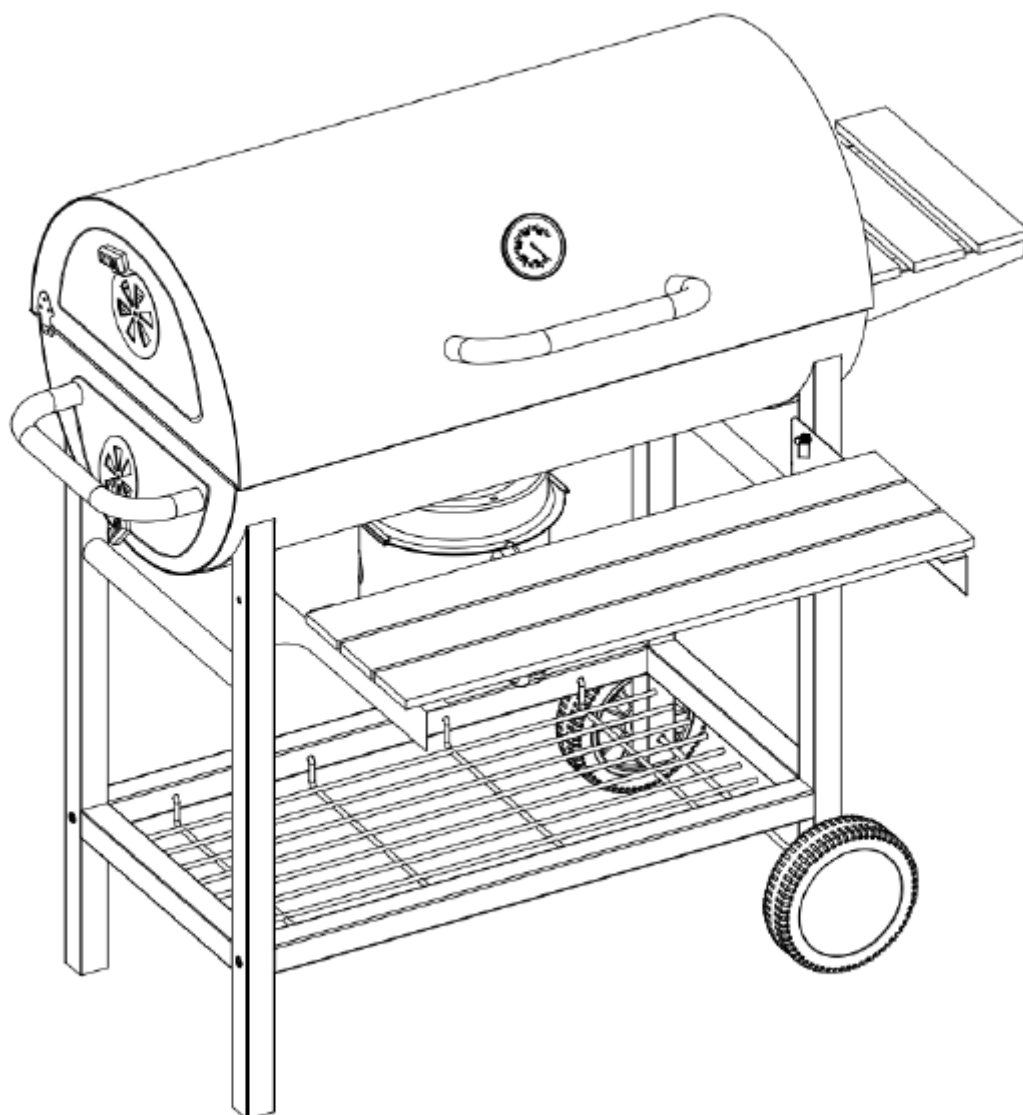











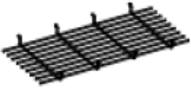

























Návod k montáži – Zahradní gril na dřevěné uhlí HYD-ZG-C GDU09-A1



1		2x	10		1x	19		2x
2		1x	11		1x	20		2x
3		1x	12		1x	21		1x
4		1x	13		2x	22		1x
5		1x	14		2x	23		2x
6		2x	15		4x			
7		1x	16		1x			
8		1x	17		1x			
9		1x	18		2x			

A		M6x45	4x	I		M6x35	4x
B		M8	2x	J		M5x10	6x
C		M6x12	16x	K		M6x16	6x
D		M6	28x	L		M5	6x
E		M6x16	2x	M		M6x12	24x
F		M6 x20	2x	N		M6	2x
G		M5	16x	O		M6x25	2x
H		M6x20	4x				

Krok 1

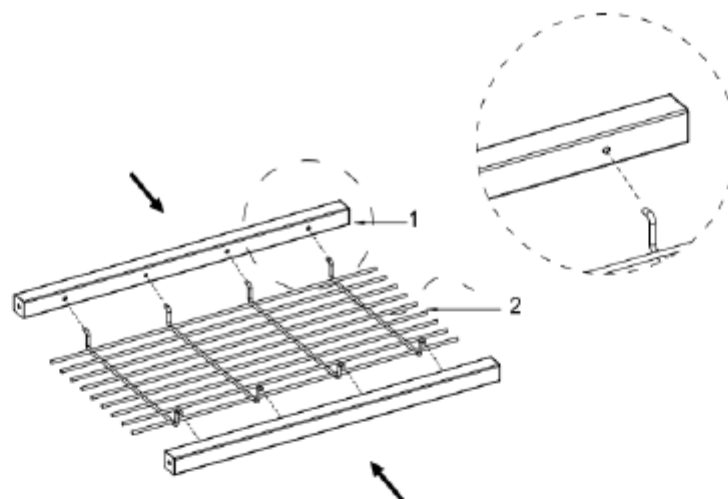

Krok 2

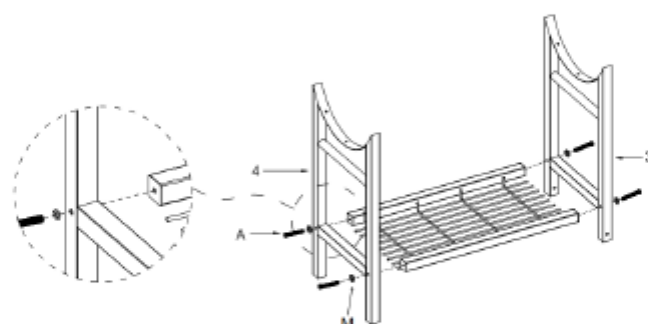

A: ⊕ ■ M6x45 4x
M: ⊙ | M6x12 4x

Krok 3

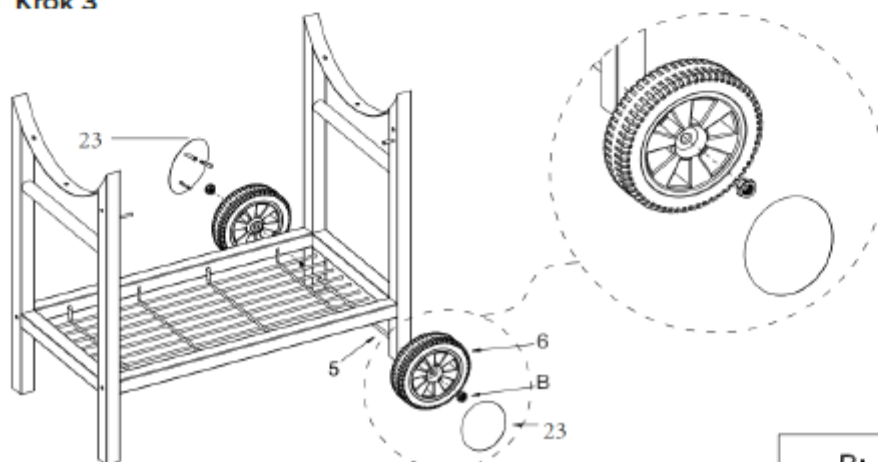

B: ⊕ M8 2 2x

Krok 4

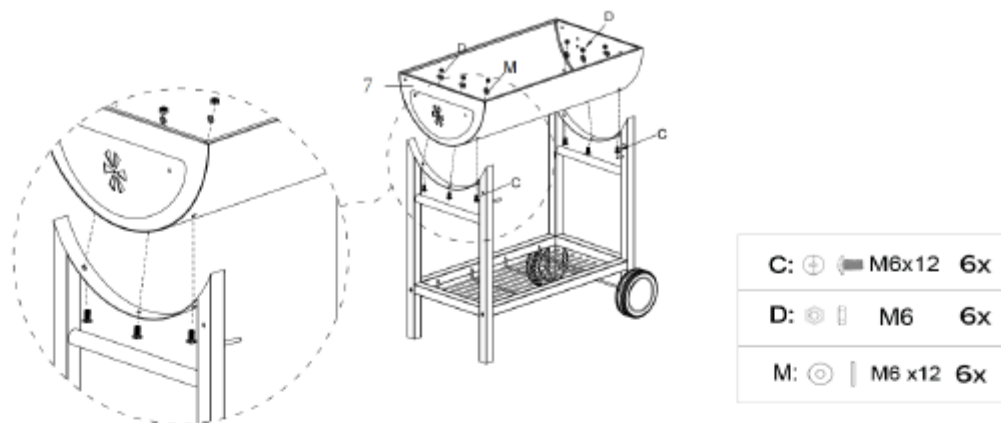

Krok 5

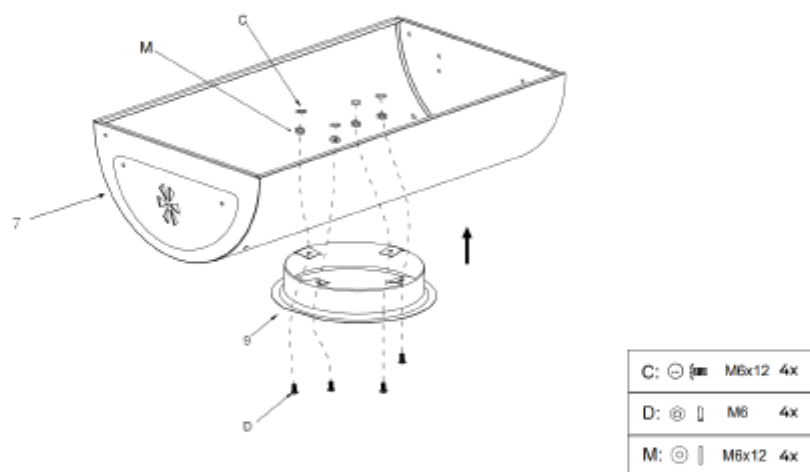

Krok 6

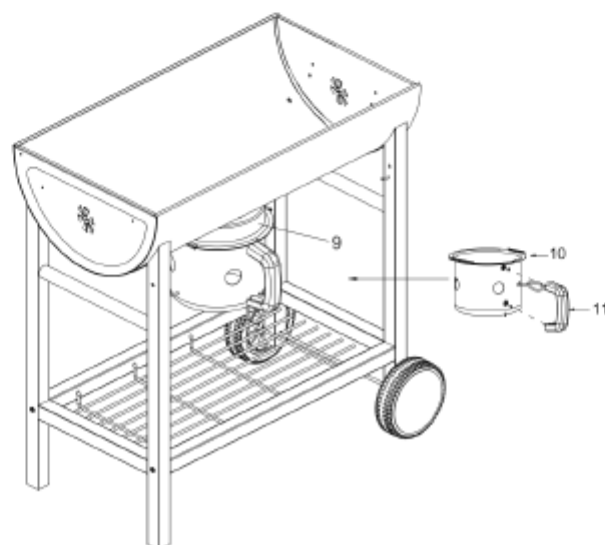

Krok 7

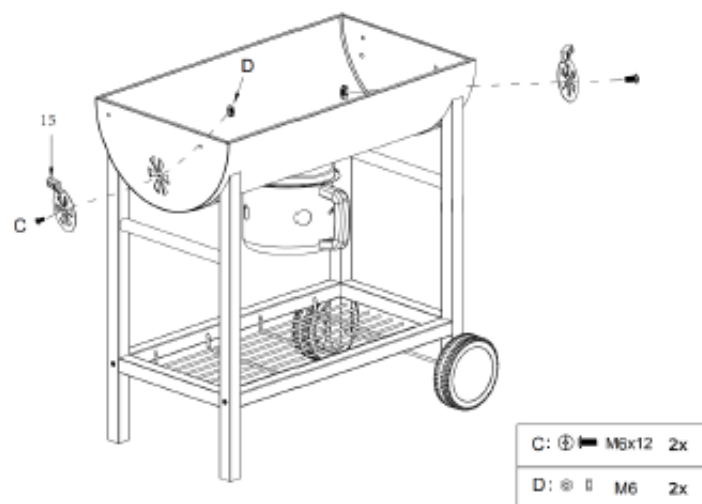

Krok 8

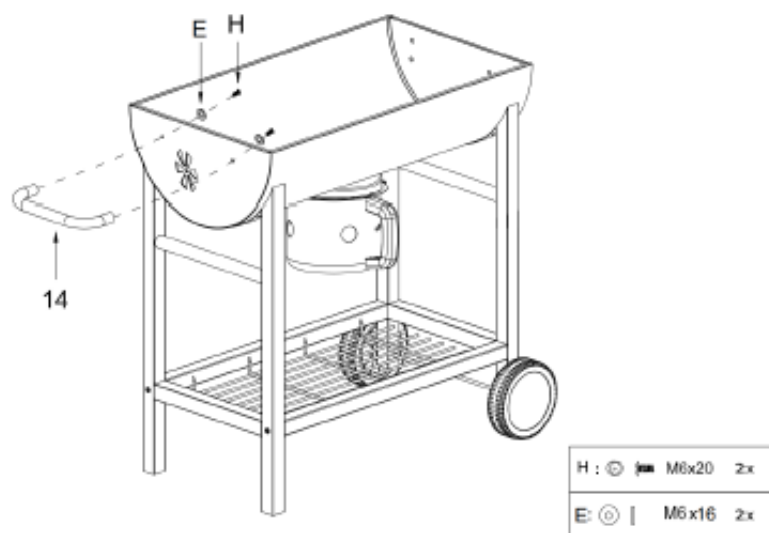

Krok 9

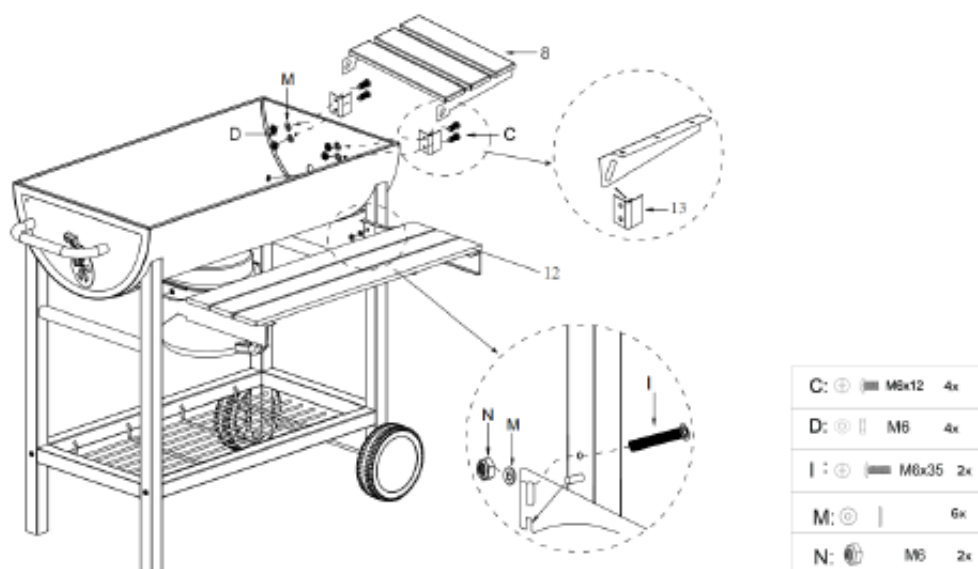

Krok 10

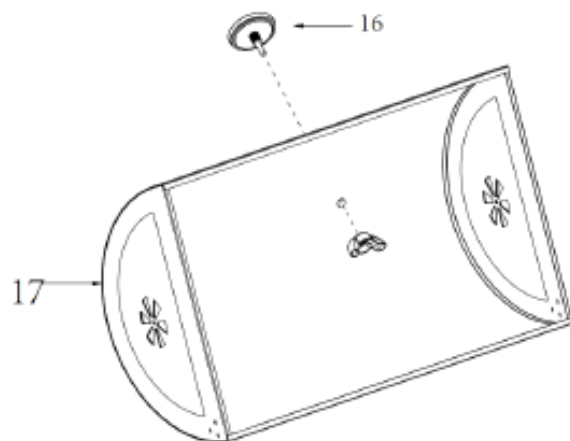

Krok 11

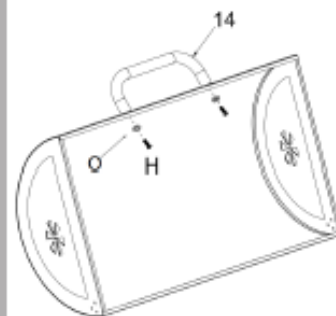

H: ⊕	■	M6x20	2x
O: ⊙	○	M6x25	2x

Krok 12

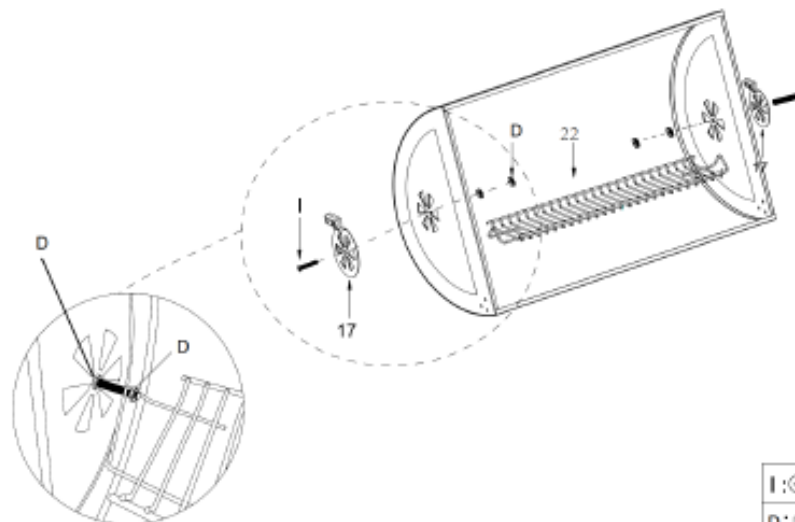

I: ⊕	■	M6x35	2x
D: ⊙	○	M6	4x

Krok 13

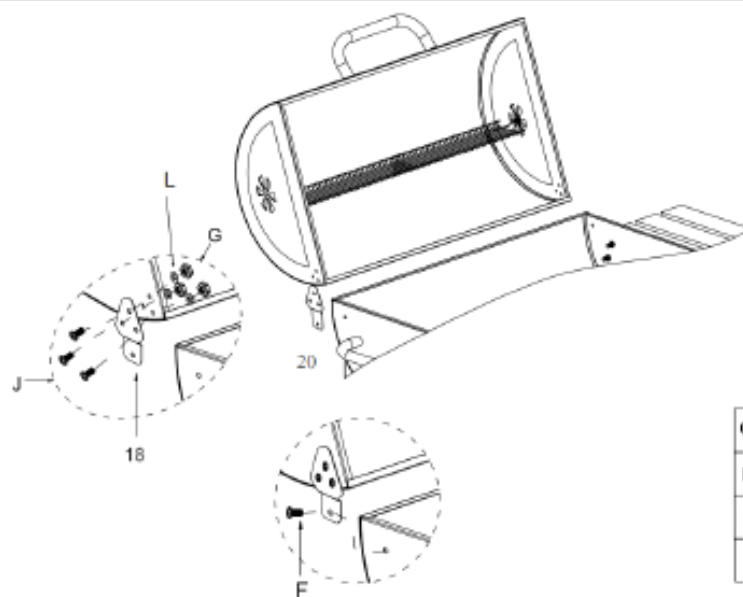

G: ⊙	■	M5	6x
F: ⊕	⊙	M6x20	2x
J: ⊕	■	M5x10	6x
L: ⊙		M5	6x

Krok 14

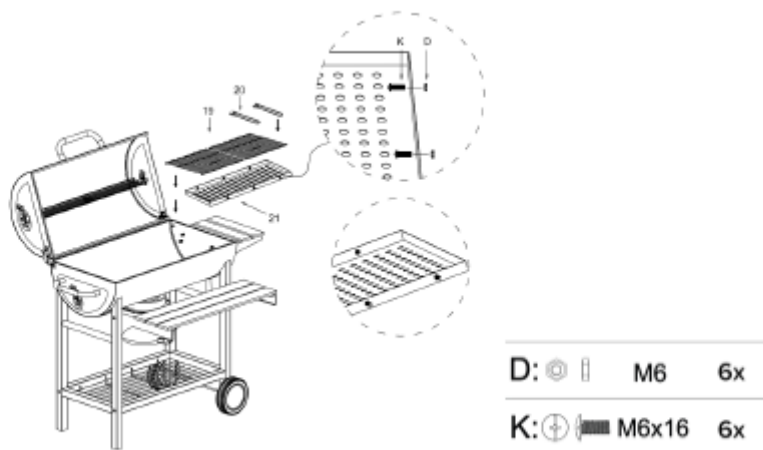

Poučení:

- K zapalování nepoužívejte líh ani benzín a po zhasnutí znovu nezapalujte!
- Uchovávejte mimo dosah dětí a domácích zvířat!
- Pevně a bezpečně sešroubovaný gril postavte na vodorovný, rovný a stabilní povrch.
- Neměňte polohu roštu, pokud jsou na něm potraviny.
- Horký rošt držte v ochranné rukavici, nikdy ne nechráněnou rukou.
- Po skončení grilování se popel uhasí vodou nebo se zakope do země.
- Pokud necháte popel v grilu, hrozí nebezpečí požáru!
- Při prvním použití je třeba gril řádně zahřát a udržovat palivo v žhavém stavu.
- Jako palivo používejte dřevěné uhlí nebo dřevěné brikety. Maximální množství paliva nesmí překročit kapacitu topeniště. Palivo nesmí přesahovat horní okraj topeniště.
- Zapalte oheň pomocí pevných podpalovačů. Na podpalovač položte několik uhelných briket a zapalte podpalovač. Jakmile oheň vzplane, přidejte palivo v požadovaném množství.
- Potraviny vkládejte na gril až po řádném rozezhřátí dřevěného uhlí.

Gril může být velmi horký, během provozu s ním nehýbejte! Nepoužívejte v interiéru!

